

PLAN

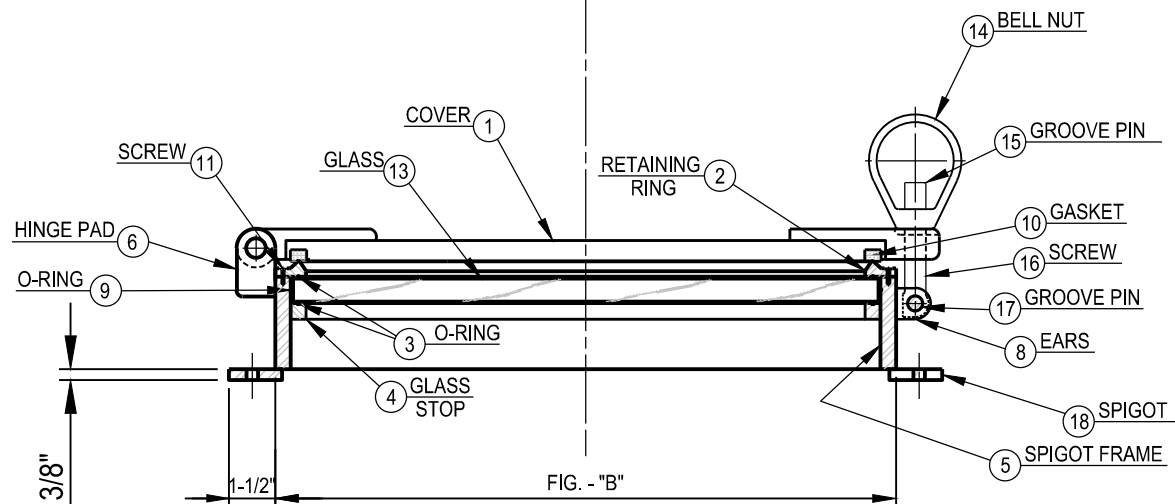

SECTION

SCHEDULE OF MATERIALS

PC.	MATERIAL	REMARKS
1	MILD STEEL	1/2" THK.
2	BRASS	
3	NEOPRENE	3/16"Ø
4	MILD STEEL	
5	MILD STEEL	1/2" x 3"
6	MILD STEEL	
7	BRASS	
8	MILD STEEL	
9	NEOPRENE	1/4"Ø
10	NEOPRENE	
11	STAINLESS	10-32x3/4" LONG
12	STAINLESS	
13	GLASS	3/4" THK. TEMPERED
14	BRONZE	
15	STAINLESS	
16	BRONZE	
17	STAINLESS	
18	MILD STEEL	3/8" THK.

DIMENSION SCHEDULE

SIZE:	10	12	14	16	18
A	10	12	14	16	18
B	12	14	16	18	20
C	11 7/16	13 7/16	15 7/16	17 7/16	19 7/16
D	33/64"	33/64"	33/64"	33/64"	33/64"
E	13 1/2"	15 1/2"	17 1/2"	19 1/2"	21 1/2"
F	15"	17"	19"	21"	23"
# OF HOLES:	10	12	12	12	12

CEN-TEX MARINE FABRICATORS, INC.

SMITHVILLE, TEXAS

STEEL BOLT ON - FIXED LIGHT

DWG. NO.: 601