

**NOTES:**

1. AFTER INSTALLATION, A 1" DIAMETER DRAIN HOLE MUST BE INSTALLED AT THE LOW POINT IN THE HINGE BOX AND DRAINED OVERBOARD OR TO A SUMP TO PREVENT CORROSION OR LEAKAGE. (BY OTHERS)

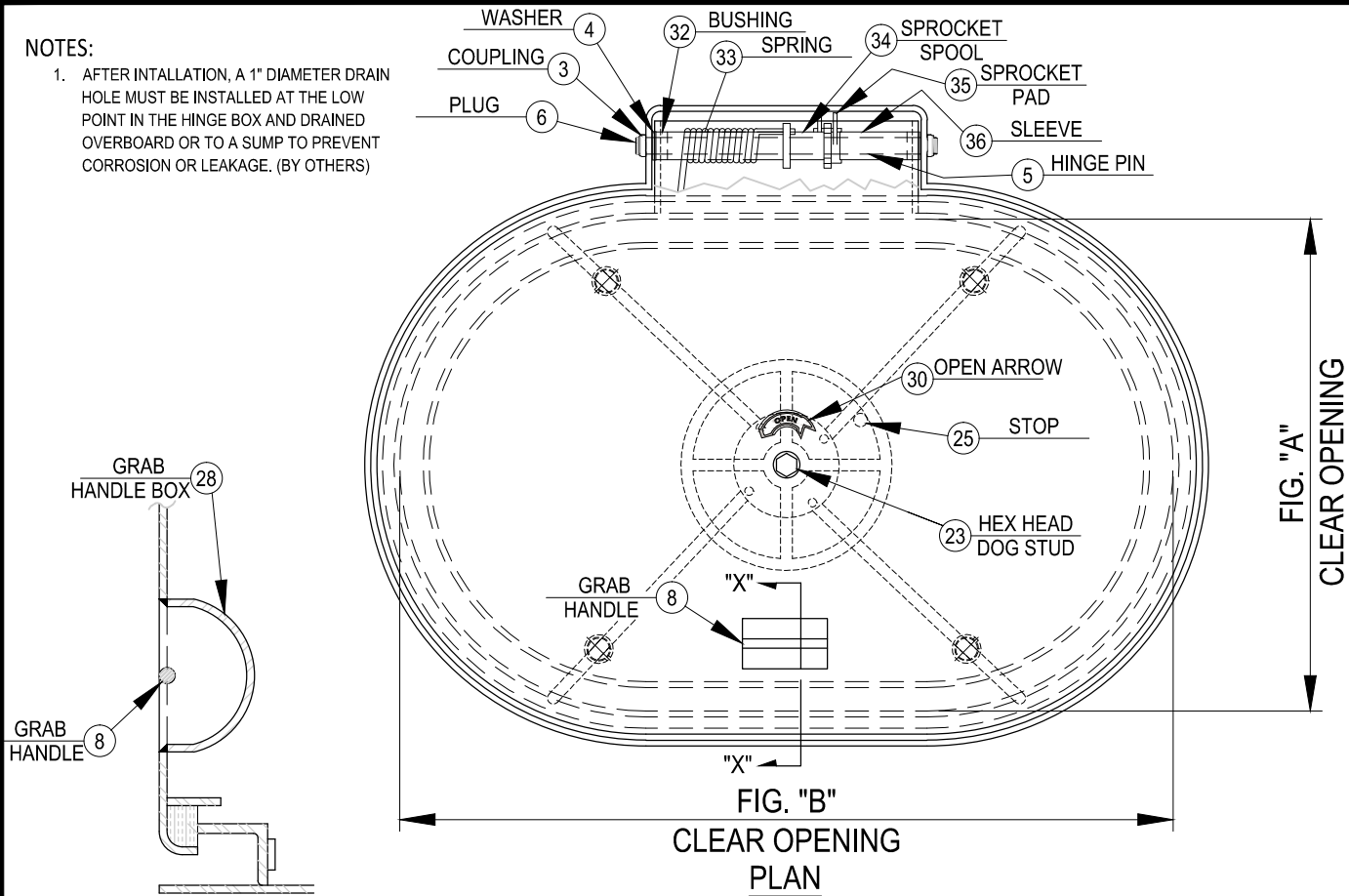

**SECTION 'X-X'**

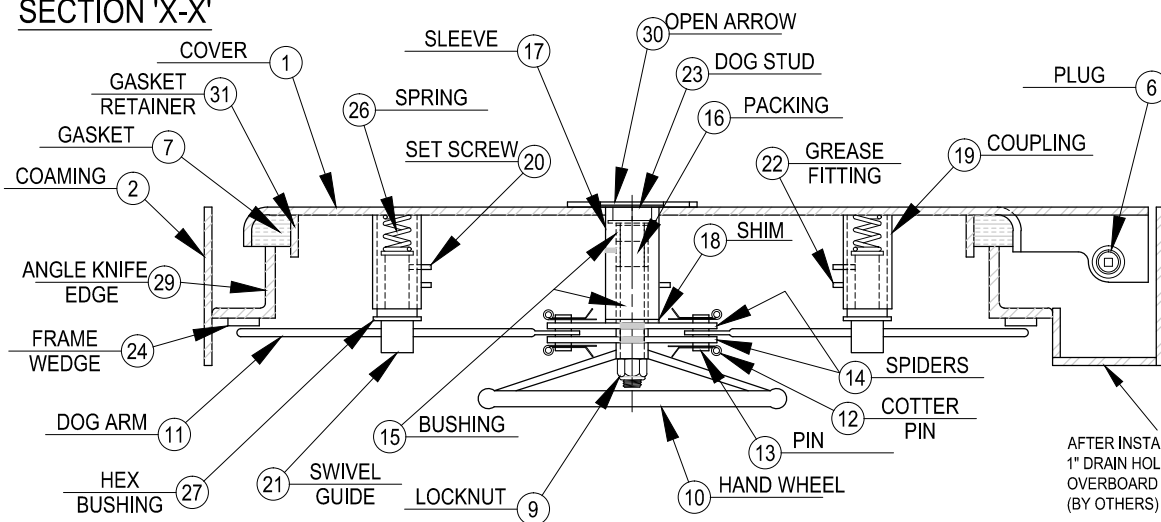

AFTER INSTALLATION, A 1" DRAIN HOLE PLUMBED OVERBOARD OR SUMP. (BY OTHERS)

**SCHEDULE OF MATERIALS**

PC.	MATERIAL	REMARKS
1	MILD STEEL	
2	MILD STEEL	
3	MILD STEEL	
4	STAINLESS	
5	COLD FINISH	
6	STEEL	
7	NEOPRENE	
8	MILD STEEL	
9	STAINLESS	
10	MILD STEEL	
11	COLD FINISH	
12	STAINLESS	
13	BRASS	
14	MILD STEEL	
15	DELTRIN	
16	TEFLON	
17	MILD STEEL	
18	STAINLESS	
19	MILD STEEL	
20	PLATED STEEL	
21	BRASS	
22	PLATED STEEL	
23	BRASS	
24	STAINLESS	
25	MILD STEEL	
26	PLATED STEEL	
27	BRASS	
28	MILD STEEL	
29	MILD STEEL	
30	STAINLESS	316L ALLOY
31	MILD STEEL	
32	BRONZE	
33	STAINLESS	
34	MILD STEEL	
35	MILD STEEL	
36	MILD STEEL	

**CEN-TEX MARINE FABRICATORS, INC.**

SMITHVILLE, TEXAS

FLUSH QUICK ACTING OVAL WATERTIGHT HATCH WITH RECESSED SPRING

DWG. NO.: 223-MS