

DETAIL OF GRAB HANDLE

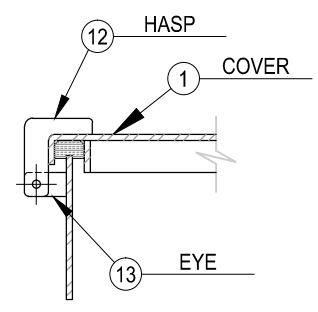

DETAIL OF HASP & EYE

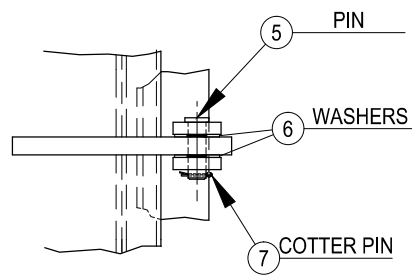

DETAIL OF HINGE

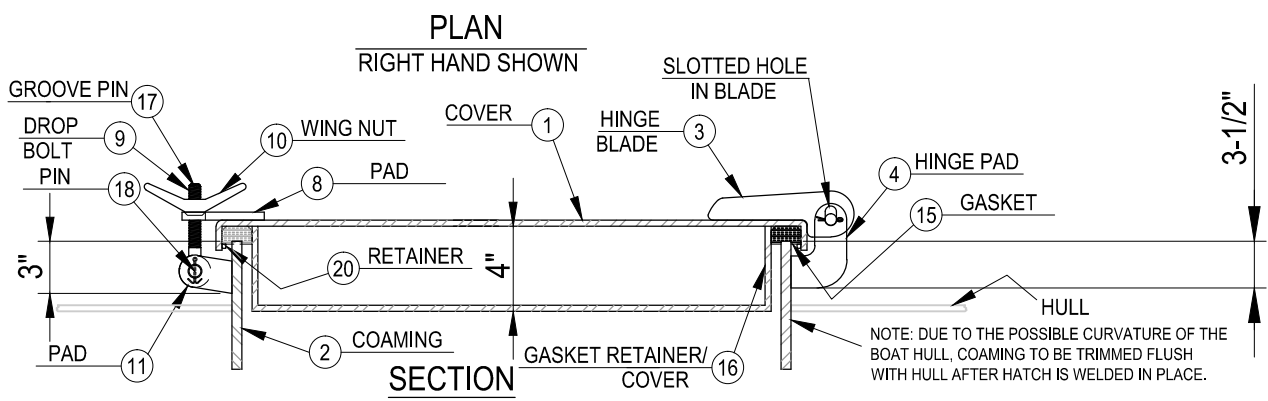

SCHEDULE OF MATERIALS		
PC.	MATERIAL	REMARKS
1	MILD STEEL	3/8" THK.
2	MILD STEEL	5/8" THK. x 8" F.B.
3	MILD STEEL	
4	MILD STEEL	
5	BRASS	
6	STAINLESS	
7	STAINLESS	
8	MILD STEEL	
9	BRONZE	
10	BRONZE	
11	MILD STEEL	
12	MILD STEEL	
13	MILD STEEL	
14	MILD STEEL	
15	NEOPRENE	3/4" THK. x 1-3/4" WIDE
16	MILD STEEL	3/8" THK.
17	STAINLESS	
18	BRASS	
19	MILD STEEL	3/8" x 3-5/8" F.B.
20	MILD STEEL	1/4" SQUARE BAR

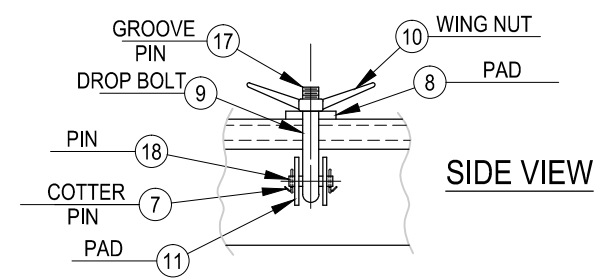

CEN-TEX MARINE FABRICATORS, INC.

SMITHVILLE, TEXAS

HULL SIDE HATCH w/DROP BOLTS

DWG. NO.: 213-MS